

P-250iA™ Series Paint Robot

FANUC
Robotics

Basic Description

FANUC Robotics' P-250iA series paint robots offer the industry's best solution for your large and mid-size painting needs. In addition to providing the industry's best work envelope and motion performance, they offer many features that enable maximum throughput, optimal quality, and low operating costs.

The P-250iA is designed for efficient process equipment integration with features such as a hollow wrist, an option for two motors on the outer arm for gear pumps, an outer arm designed for easy integration of paint application equipment and multiple hose routing options.

The P-250iA is available in both the P-250iA /15™ full-size arm and mid-size arm P-250iA /10S™ to right size the robot for the application. The robot can also be mounted for elevated, in-booth and clean wall floor style rails. This flexibility provides maximum use of the product in a variety of applications.

An excellent replacement for manual sprayers and older automation, the P-250iA robot (with optional rail solutions) provides a reach that gives process flexibility to maintain precise target distances and gun orientations over the largest of parts – maximizing quality.

Features & Benefits

- Floor, wall and invert mounting permits access to even the hardest-to-reach areas of parts, when required
- Patented, production proven, hollow wrist and through-arm hose routing provide a clean application environment
- Options for either in-arm gear pump or mounting space for an in-arm flow meter and color valves provide



fluid delivery flexibility with minimized color change time and material waste

- Flex field hose makes for fast installation
- Alternate Roxtec seal for CE Mark installation
- Ability to “flip-over” axis 2 and 3 to provide a very large work envelope and maximum flexibility for painting
- Payload sized to carry a variety of applicators including conventional and electrostatic air spray guns and rotary atomizers
- Optional ROBOGUIDE® PaintPRO™ software is a user-friendly Windows®-based graphical programming interface for creating, viewing, editing and simulating robot programs

Plastic Arm

- Allows for paint equipment to be mounted on a non-grounded arm
- Reduces grounded surfaces keeping arm cleaner

Elevated Rail

- Family of standard support columns provide multiple robot height options
- Supports on-site elevation adjustment
- Robust rack and pinion rail drive
- Optional cat track location of side or top depending upon booth requirements
- Vertical bearing positioning with cover to eliminate grease drips from the rail

Floor Rail

- In-booth and clean wall options
- Supports pedestal robot mounting
- Optional robot riser rather than lifting entire rail unit
- Adjustable mounting pads with leveling screws
- Robust rack and pinion rail drive
- Removable covers for in booth design

Process Advantages

- Two component IPC Gear Pump Metering
- User-friendly ACCUFLOW™ and AccuChop™ closed loop fluid delivery systems automatically maintains programmed flow rates, providing consistent material delivery and high finish quality
- Able to utilize manifold mount robot spray guns and rotary atomizers
- Extremely fast acceleration and deceleration motion results in faster cycle times.

Reliability and Maintenance Advantages

- Designed for painting environment
- 15th generation P-250iA/10S designed with production proven reliability
- Internally and externally sealed wrist
- Large wrist aperture

Software

- Line tracking
- Automatic color change
- Analog parameter control
- Integral two-component variable ratio or one-component pump control
- ACCUFLOW closed loop fluid control for paint applications
- AccuChop closed loop fluid control for FRP applications
- Collision Guard™



P-250iA Plastic Arm Option Robot

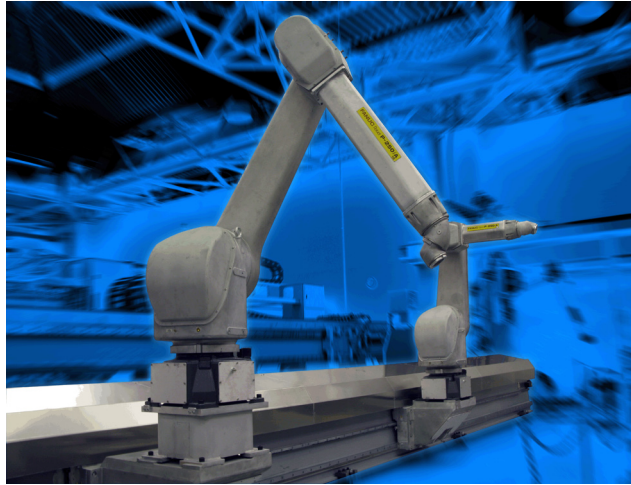

P-250iA Floor Rail



P-250iA/15 Elevated Rail



P-250iA/10S Robot

P-250iA/15 Dimensions

Isometric

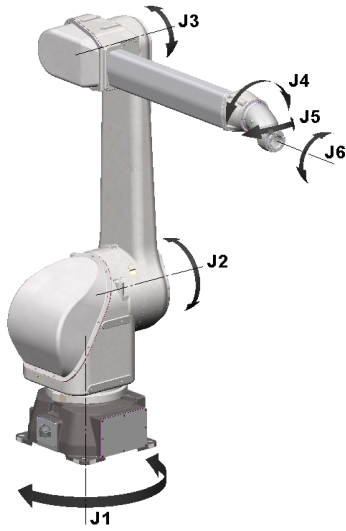

Top

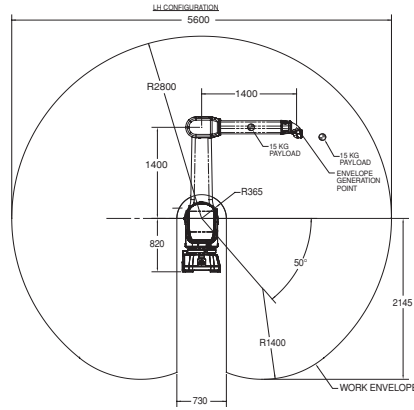
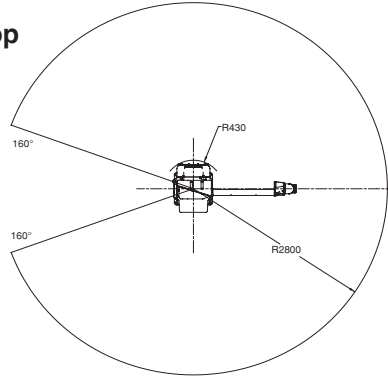

Side

Wrist

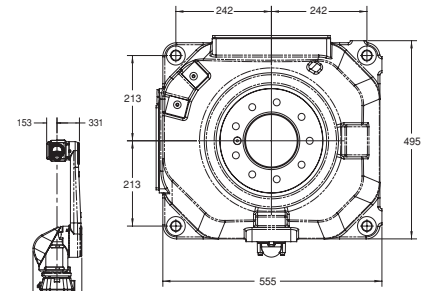
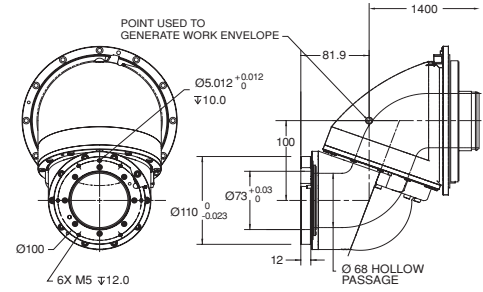

Footprint

Front

P-250iA/10S Dimensions

Isometric

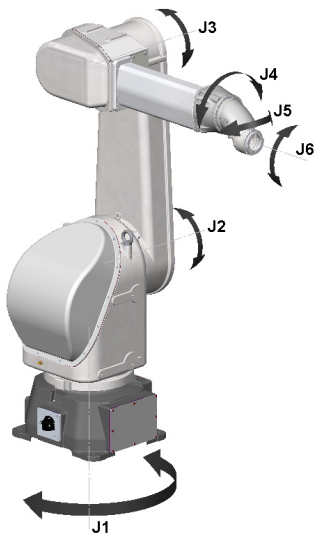

Top

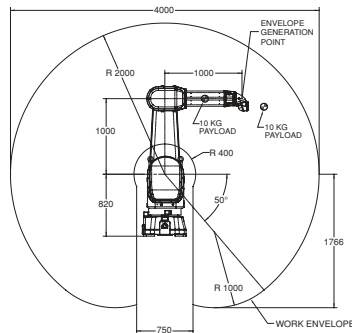
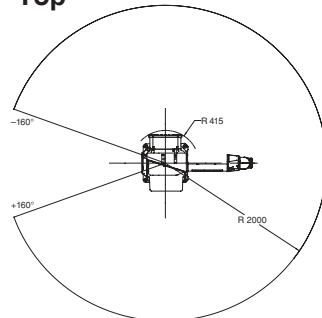

Side

Wrist

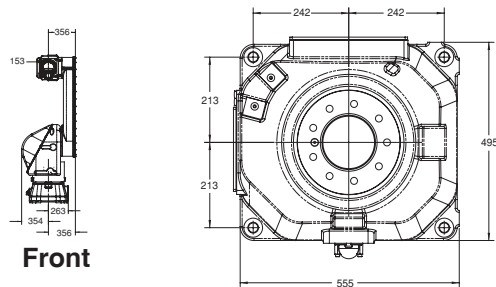
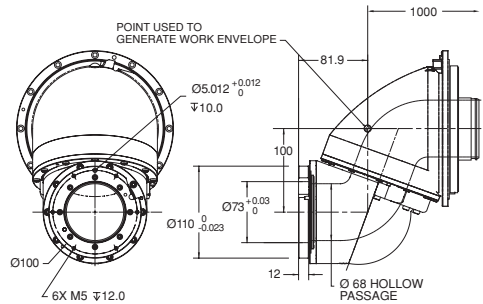

Footprint

Note: Dimensions are shown in millimeters.
Detailed CAD data are available upon request.

P-250iA Floor Rail Dimensions

Isometric

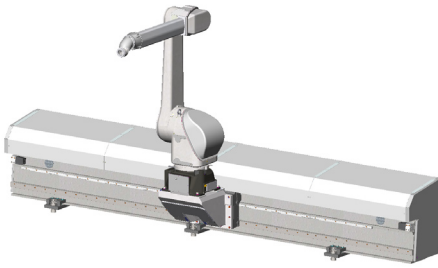

Front

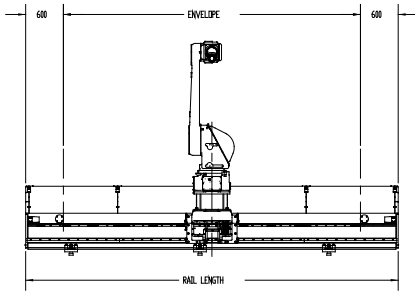

Top

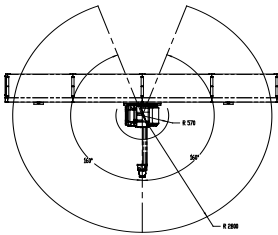

Side

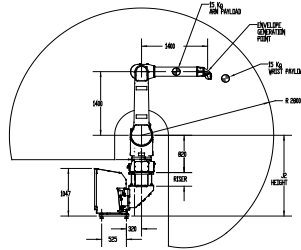

P-250iA Elevated Rail Dimensions

Isometric

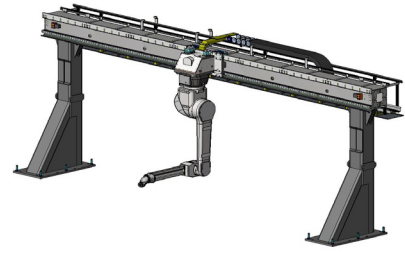

Front

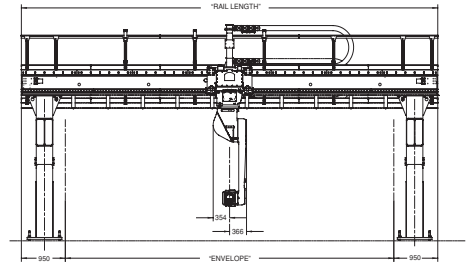

Top

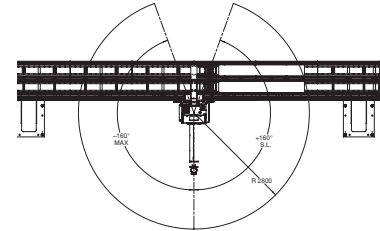

Side

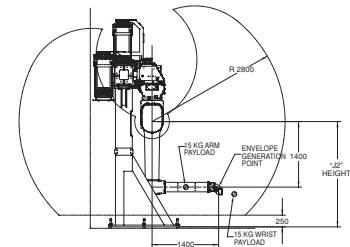

P-250iA Specifications

Items	P-250iA/10S	P-250iA/15
Axes	6	6
Payload - wrist (kg) ⁽²⁾	10	15
Outer arm payload	10	15
Reach (mm)	2000	2800
Repeatability (mm)	±0.2	±0.2
Motion range (degrees)	J1 ⁽³⁾	320
	J2	280
	J3	310
	J4	1080
	J5	1080
	J6	1080
Coating Speed	1500 mm / sec	
Mechanical brakes	Axis 2, 3 (option 1, 4, 5, 6)	
Mechanical weight (kg)	495	520
Mounting method	Floor, ceiling and wall	
Hazardous Location Certification	Class I, II, III Div. I Group C, D, E, F, G	
	ATEX CE II 2 G c Ex ib px IIB T4 Ta=0°C to +45°C ATEX CE II 2 D c Ex pD 21 T135°C Ta=0°C to +45°C	

Notes:

- (1) Optional high speed wrist (550, 550, 710 degrees/s)
- (2) At 300 mm axial, 50 mm radial offset. Please contact FANUC Robotics for high speed wrist payload.
- (3) Wall mount has reduced envelope. Please contact FANUC Robotics for more information.

Note: Dimensions are shown in millimeters.
Detailed CAD data are available upon request.

Intelligent Robot Solutions

FANUC Robotics America, Inc.
3900 W. Hamlin Road
Rochester Hills, MI 48309-3253
(248) 377-7000

For sales or technical information, call:
1-800-iQ-ROBOT

marketing@fanucrobotics.com
fanucrobotics.com

Charlotte, NC
(704) 596-5121

Chicago, IL
(847) 898-6000

Cincinnati, OH
(513) 754-2400

Los Angeles, CA
(949) 595-2700

Toledo, OH
(419) 866-0788

FANUC
Robotics

Toronto, Canada
(905) 812-2300

Montréal, Canada
(450) 492-9001

Aguascalientes, Mexico
52 (449) 922-8000

Sao Paulo, Brazil
(55) (11) 3619-0599

©2009 FANUC Robotics America, Inc. All rights reserved. FANUC ROBOTICS LITHO IN U.S.A. FRA-12/09



For further information contact Motion Controls Robotics at 419.334.5886